

MAIN CHARACTERISTICS

| | |
|--|-------|
| I_D | 11A |
| V_{DS} | 800V |
| $R_{DS(on)-typ}$ (@VGS=18V Tc=25°C) | 370mΩ |

Features

- High Speed Switching with Low Capacitances
- High Blocking Voltage with Low RDS(on)
- Easy to paralle
- Simple to drive
- RoHS Compliant

Benefits

- Increased Power Density
- Faster Operating Freequency
- Reduction of Heat Sink Requirements
- Higher Efficiency
- Reduced EMI

Application

- Power Factor Correction Modules
- Switch Mode Power Supplies
- DC-AC Inverters
- High Voltage DC/DC Converters

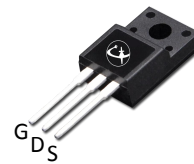
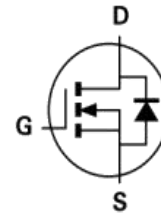

TO-220F

Product specification classification

| Part Number | Package | Mode Name | Pack |
|-------------|---------|------------|------|
| LSC380M65F | TO-220F | LSC380M65F | Tube |

Maximum Ratings at Tc=25°C unless otherwise specified

| Parameter | Symbol | Value | Unit |
|---|-----------------|-------------|------|
| Drain-Source Voltage | V_{DS} | 800 | V |
| Gate-Source Voltage | V_{GS} | -8/+22 | V |
| Recommended Operation Value | V_{GSop} | -4/+18 | V |
| Continue Drain Current TC=25°C | I_D | 11 | A |
| Continue Drain Current TC=100°C | | 8 | A |
| Pulsed Drain Current (Note1) | I_{DM} | 22 | A |
| Power Dissipation | P_D | 57 | W |
| Operating Temperature Range | T_J | -40 to +175 | °C |
| Storage Temperature Range | T_{STG} | -40 to +175 | °C |
| Thermal Resistance, Junction to Case | $R_{\theta JC}$ | 3.76 | °C/W |
| Thermal Resistance, Junction to Ambient | $R_{\theta JA}$ | 40 | °C/W |

Note1:Pulse test: 300 μ s pulse width, 2 % duty cycle

Electrical Characteristics at Tc=25°C unless otherwise specified

| Parameter | Test Condition | Symbol | Min | Typ | Max | Unit |
|----------------------------------|--|--------------|-----|------|-----|------------|
| Drain-Source Breakdown Voltage | $V_{GS} = 0 V, I_D = 100\mu A$ | BV_{DSS} | 800 | - | - | V |
| Drain-Source Leakage Current | $V_{DS} = 800 V, V_{GS} = 0 V$ | I_{DSS} | - | 1 | - | μA |
| Gate Leakage Current | $V_{GS} = 18 V, V_{DS} = 0 V$ | I_{GSS} | - | - | 250 | nA |
| Gate-Source Threshold Voltage | $V_{DS} = V_{GS}, I_D = 1.33 mA$ | $V_{GS(th)}$ | 2 | 3.1 | 4 | V |
| Drain-Source On-State Resistance | $V_{GS} = 15 V, I_D = 4.5 A$ | $R_{DS(on)}$ | - | 398 | 550 | m Ω |
| | $V_{GS} = 15 V, I_D = 4.5 A, T_J = 175^\circ C$ | | - | 340 | - | |
| | $V_{GS} = 18 V, I_D = 4.5 A$ | | - | 370 | 485 | |
| | $V_{GS} = 18 V, I_D = 4.5 A, T_J = 175^\circ C$ | | - | 410 | - | |
| Input Capacitance | $V_{GS} = 0 V, V_{DS} = 600 V, f = 1MHz$ | C_{iss} | - | 203 | - | pF |
| Output Capacitance | | C_{oss} | - | 26 | - | pF |
| Reverse Transfer Capacitance | | C_{rss} | - | 3.5 | - | pF |
| Internal Gate Resistance | $f=1MHz$ | $RG(int)$ | - | 3.6 | - | Ω |
| Total Gate Charge(Note2) | $I_D = 4.5 A, V_{DD} = 400 V, V_{GS} = -4/18 V$ | Q_G | - | 11.2 | - | nC |
| Gate to Source Charge(Note2) | | Q_{GS} | - | 2 | - | nC |
| Gate to Drain Charge(Note2) | | Q_{GD} | - | 5.2 | - | nC |
| Turn-on Delay Time(Note2) | $V_{DS} = 400 V, I_D = 4.5 A, V_{GS} = -4/18 V, RG = 2.5 \Omega$ | $t_{d(ON)}$ | - | 3 | - | ns |
| Rise Time(Note2) | | t_r | - | 8 | - | ns |
| Turn-Off Delay Time(Note2) | | $t_{d(OFF)}$ | - | 6 | - | ns |
| Fall Time(Note2) | | t_f | - | 11 | - | ns |
| Turn-On Energy | | E_{on} | - | 21 | - | μJ |
| Turn-Off Energy | | E_{off} | - | 5 | - | μJ |

Source-Drain Diode Characteristics at Ta=25°C unless otherwise specified

| Parameter | Test Condition | Symbol | Min. | Typ. | Max. | Unit |
|--|----------------------------|-----------------|------|------|------|------|
| Maximum Body-Diode Continuous Current | VGS=-4V Tc=25°C | I _S | - | 11 | - | A |
| | VGS=-4V Tc=100°C | | - | 6.5 | - | A |
| Maximum Body-Diode Pulsed Current(Note2) | | I _{SM} | - | - | 22 | A |
| Drain-Source Diode Forward Voltage | VGS=-4V, ISD=2.5A Tj=25°C | V _{SD} | - | 4 | - | V |
| | VGS=-4V, ISD=2.5A Tj=175°C | | - | 3.6 | - | V |
| | VGS=-4V, ISD=4.5A Tj=25°C | V _{SD} | - | 4.5 | - | V |
| | VGS=-4V, ISD=4.5A Tj=175°C | | - | 4 | - | V |
| Reverse Recovery Time(Note2) | VGS=-4V, ISD=4.5A, | trr | - | 10 | - | ns |
| Reverse Recovery Charge(Note2) | VR=400V, di/dt=1000A/μs | Qrr | - | 56 | - | nC |
| Peak Reverse Recovery Current | | Irrm | - | 4 | - | A |

Note2:Pulse test: 300 μs pulse width, 2 % duty cycle

RATINGS AND CHARACTERISTIC CURVES

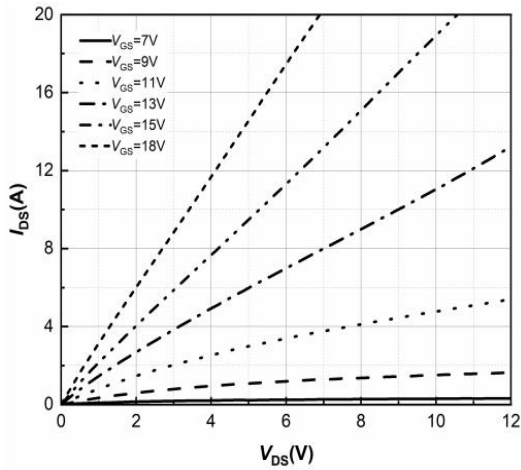

Figure 1. Output Characteristics
 $T_j = -40^\circ\text{C}$

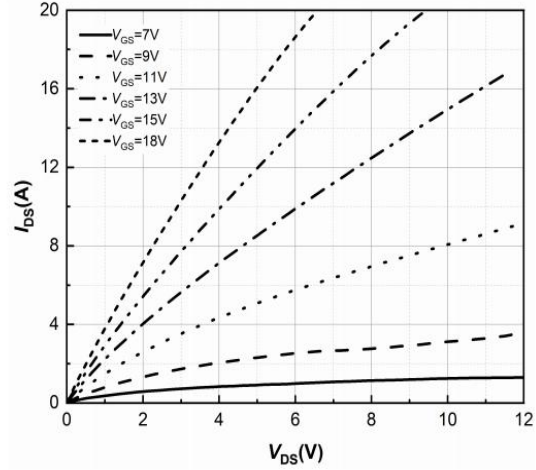

Figure 2. Output Characteristics

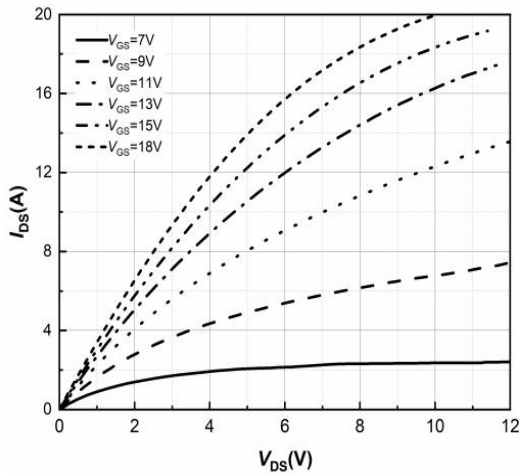

Figure 3. Output Characteristics
 $T_j = 175^\circ\text{C}$

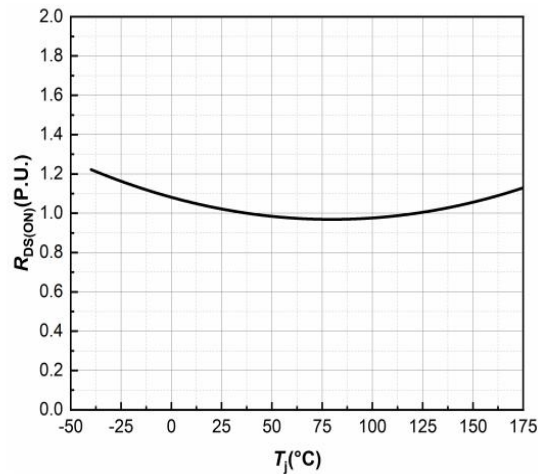

Figure 4. Normalized On-Resistance vs. Temperature

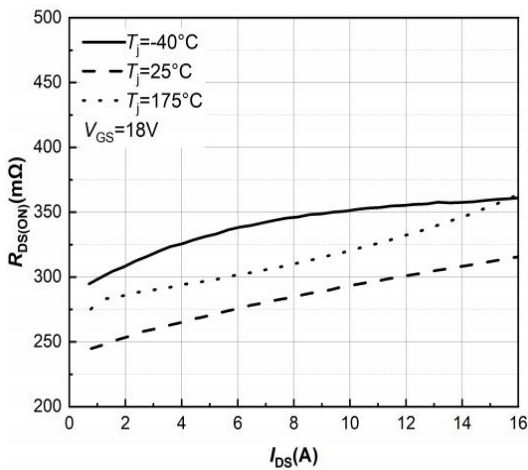

Figure 5. On-Resistance vs. Drain Current For Various Temperatures

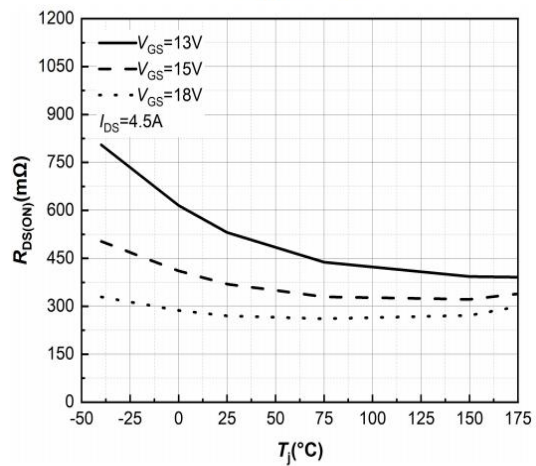

Figure 6. On-Resistance vs. Temperature For Various Gate Voltage

RATINGS AND CHARACTERISTIC CURVES

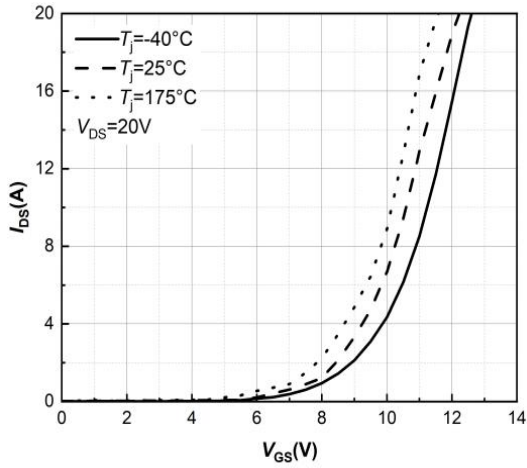

Figure 7. Transfer Characteristic for Various Junction Temperatures

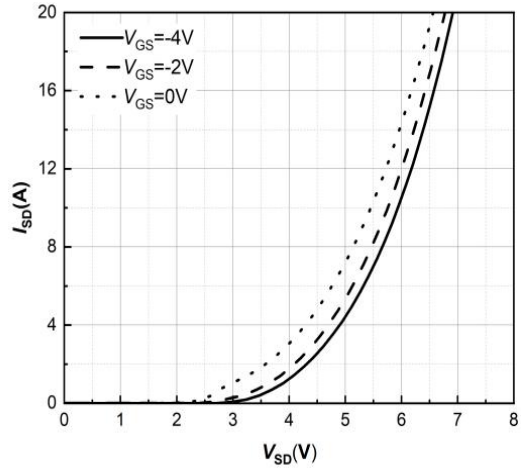

Figure 8. Body Diode Characteristic $T_J = -40^\circ\text{C}$

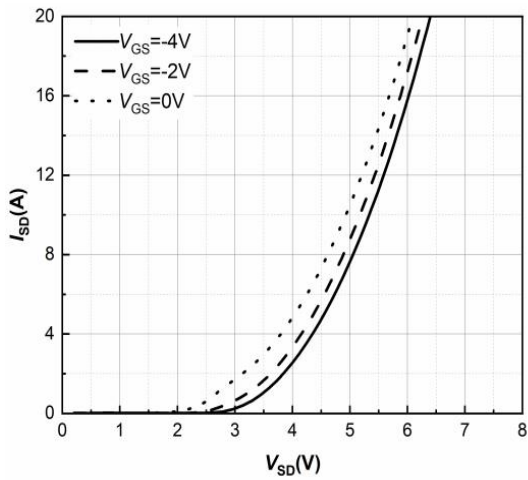

Figure 9. Body Diode Characteristic $T_J = 25^\circ\text{C}$

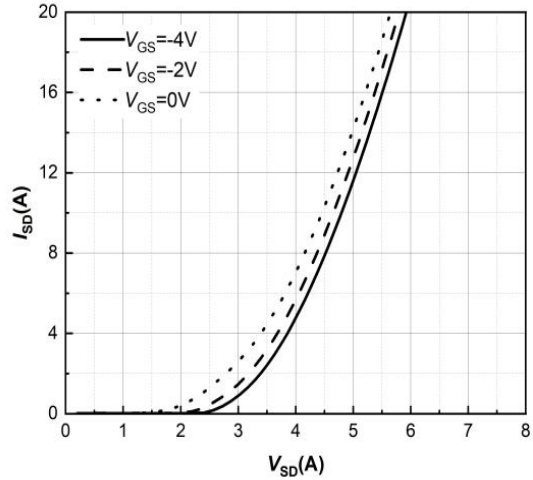

Figure 10. Body Diode Characteristic $T_J = 175^\circ\text{C}$

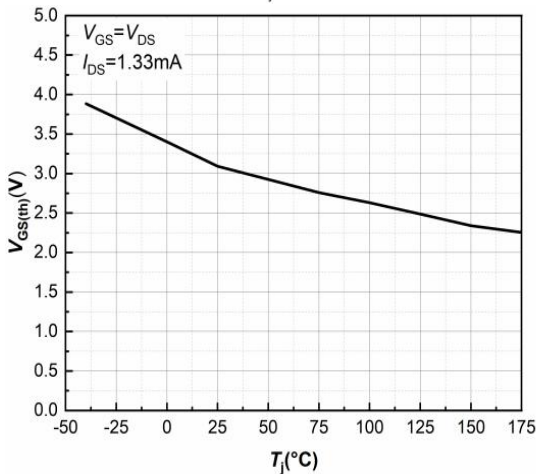

Figure 11. Threshold Voltage vs. Temperature

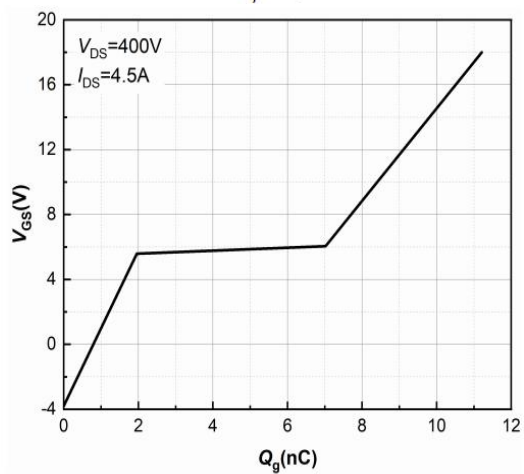

Figure 12. Gate Charge Characteristics

RATINGS AND CHARACTERISTIC CURVES

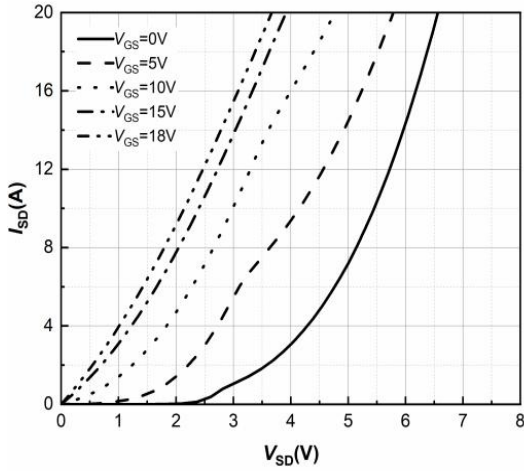

Figure 13. 3rd Quadrant Characteristic
 $T_j = -40^\circ\text{C}$

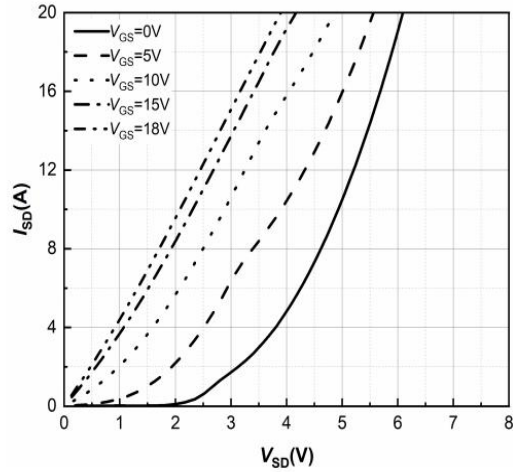

Figure 14. 3rd Quadrant Characteristic
 $T_j = 25^\circ\text{C}$

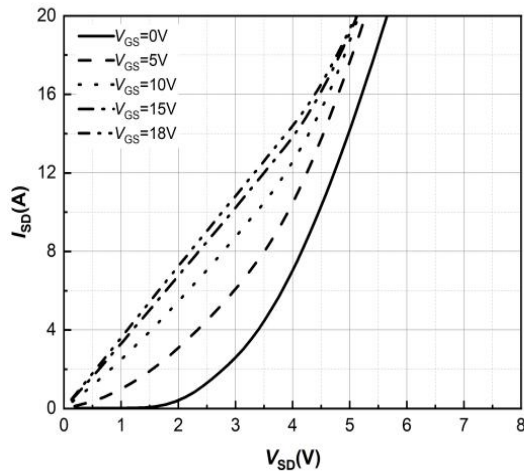

Figure 15. 3rd Quadrant Characteristic
 $T_j = 175^\circ\text{C}$

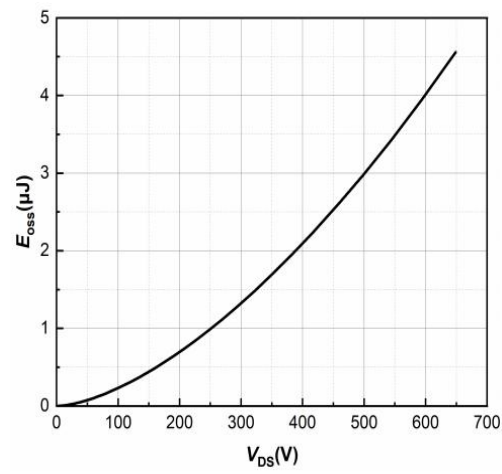

Figure 16. Output Capacitor Stored Energy

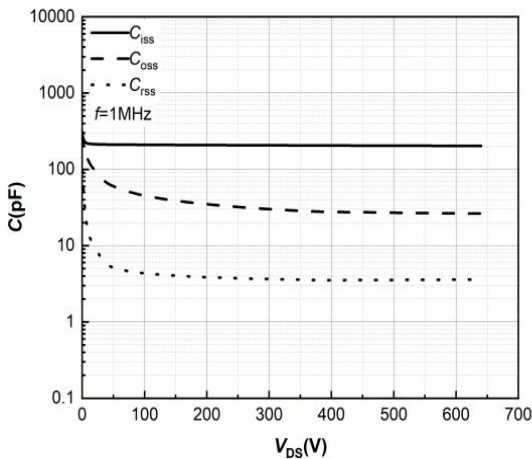

Figure 17. Capacitances vs. Drain-Source

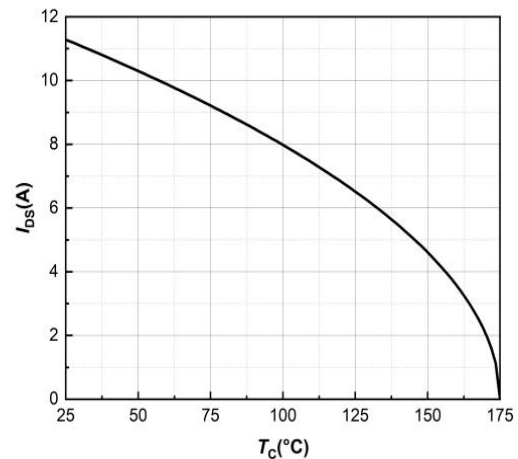

Figure 18. Continuous Drain Current Derating vs. Case Temperature

RATINGS AND CHARACTERISTIC CURVES

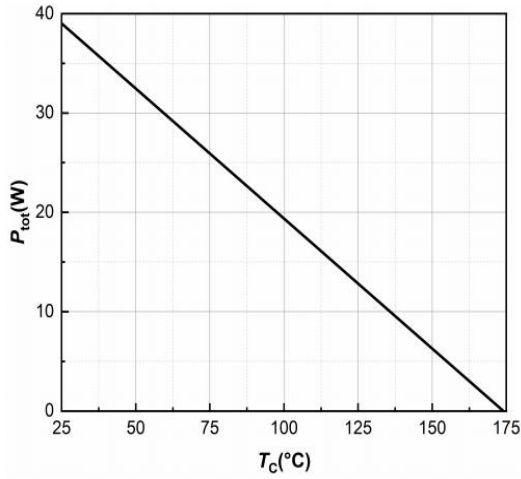

Figure 19. Maximum Power Dissipation Derating vs. Case Temperature

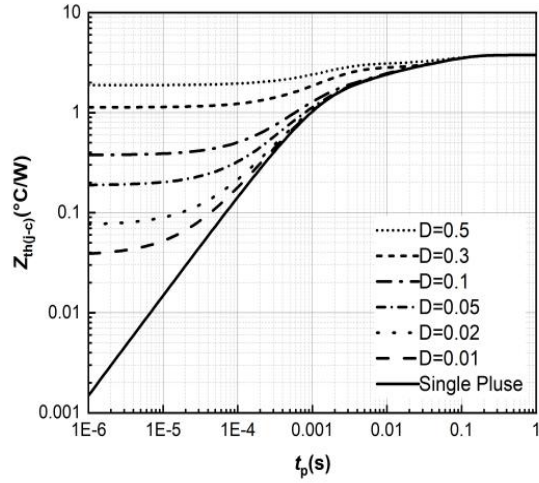

Figure 20. Transient Thermal Impedance

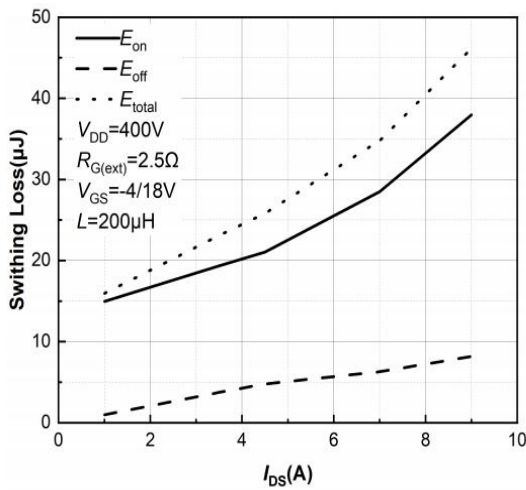

Figure 21. Clamped Inductive Switching Energy vs. Drain Current

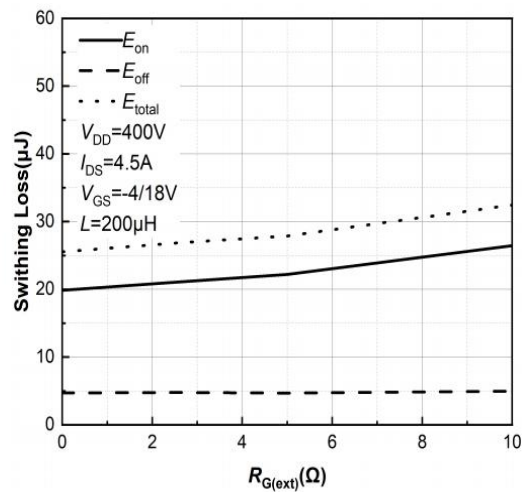

Figure 22. Clamped Inductive Switching Energy vs. R_G

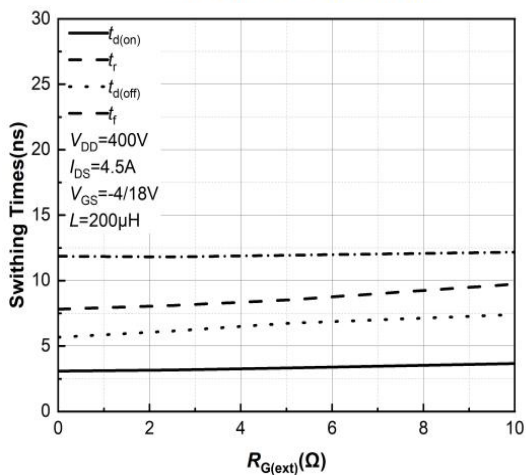

Figure 23. Switching Times vs. R_G

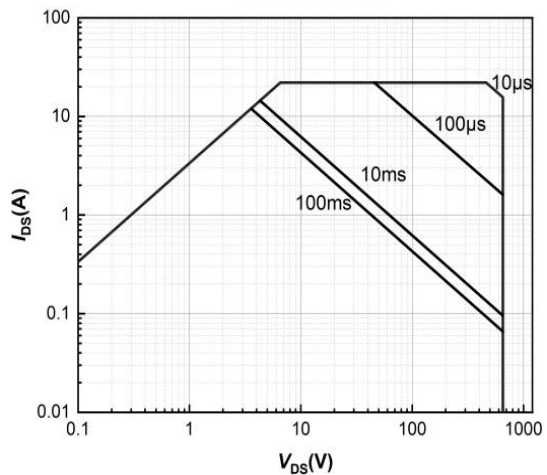
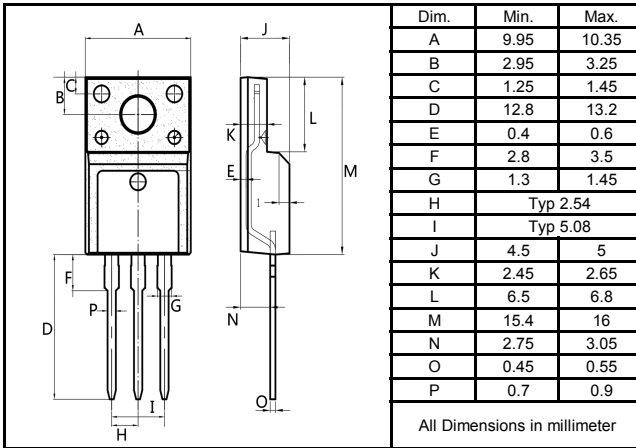

Figure 24. Safe Operating Area

Package Outline Dimensions millimeters



T0-220F

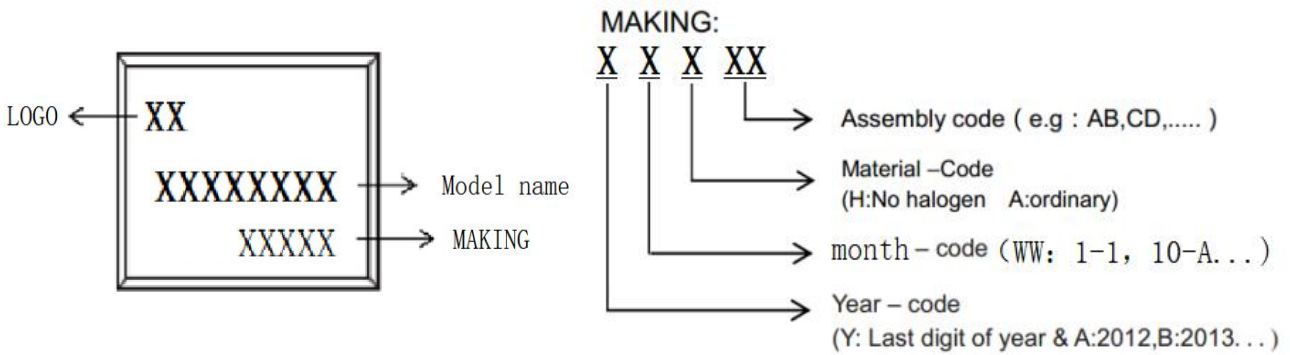

Marking on the body



packing instruction

| PKG | Minimal Package | Mini Box | Box |
|---------|---|--|---|
| TO-220F |  |  |  |
| | 50pcs/pdpe | 1000pcs/box | 5000pcs/box |

Notice

All product, product specifications and data are subject to change without notice to improve. The right to explain is owned by LINGXUN electronics company.

Confirm that operation temperature is within the specified range described in the product specification. Avoid applying power exceeding normal rated

power; exceeding the power rating under steady-state loading condition may negatively affect product performance and reliability.

LINGXUN electronics shall not be in any way responsible or liable for failure induced under deviant condition from what is defined in this document.

<http://www.lxmicro.com>

Revision History

| Rev | Changes | Date |
|-----|---------------|-----------|
| 1.0 | First version | 2026/1/13 |