

MAIN CHARACTERISTICS

I_D	94A
V_{DS}	800V
$R_{DS(on)-typ}$ (@VGS=18V Tc=25°C)	30mΩ

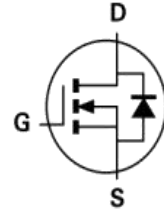

FEATURES

- High Speed Switching
- High Blocking Voltage with Low RDS(on)
- Easy to Parallel
- Simple to Drive
- RoHS Compliant

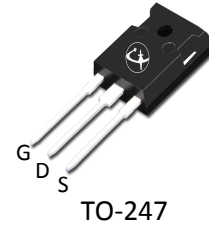

BENEFITS

- Increased Power Density
- Faster Operating Frequency
- Reduction of Heat Sink Requirements
- Higher Efficiency
- Reduced EMI

APPLICATIONS

- Power Factor Correction Modules
- Switch Mode Power Supplies
- DC-AC Inverters
- High Voltage DC/DC Converters

MECHANICAL DATA

- Case: Molded plastic
- Mounting Position: Any
- Molded Plastic: UL Flammability Classification Rating 94V-0
- Lead free in compliance with EU RoHS 2011/65/EU directive
- Solder bath temperature 275°C maximum, 10s per JESD 22-B106

Product specification classification

Part Number	Package	Mode Name	Pack
LSC040M65B	TO-247	LSC040M65B	Tube

Maximum Ratings at Tc=25°C unless otherwise specified

Parameter	Symbol	Value	Unit
Drain-Source Voltage	V_{DS}	800	V
Gate-Source Voltage	V_{GS}	-8/+22	V
Recommended Operation Value	V_{GSop}	-4/+18	V
Continue Drain Current TC=25°C	I_D	94	A
Continue Drain Current TC=100°C		66	A
Pulsed Drain Current (Note1)	I_{DM}	190	A
Power Dissipation	P_D	208	W
Non-Repetitive Avalanche Switching Energy	EAS	1012	mJ
Short-Circuit Withstand Time	tSC	3	μs
Operating Temperature Range	T_J	-40 to +175	°C
Storage Temperature Range	T_{STG}	-40 to +150	°C
Thermal Resistance, Junction to Case	$R_{\theta JC}$	0.72	°C/W

Note1:Pulse test: 300 μs pulse width, 2 % duty cycle

Electrical Characteristics at Tc=25°C unless otherwise specified

Parameter	Test Condition	Symbol	Min	Typ	Max	Unit
Drain-Source Breakdown Voltage	$V_{GS} = 0 V, I_D = 100\mu A$	BV_{DSS}	800	-	-	V
Drain-Source Leakage Current	$V_{DS} = 800 V, V_{GS} = 0 V$	I_{DSS}	-	-	1	μA
Gate Leakage Current	$V_{GS} = +18 V, V_{DS} = 0 V$	I_{GSS}	-	-	250	nA
	$V_{GS} = -4 V, V_{DS} = 0 V$		-	-	-250	nA
Gate-Source Threshold Voltage	$V_{DS} = V_{GS}, I_D = 10 mA$	$V_{GS(th)}$	2	2.6	4	V
Drain-Source On-State Resistance	$V_{GS} = 18 V, I_D = 30 A$	$R_{DS(on)}$	-	30	49	mΩ
	$V_{GS} = 18 V, I_D = 30 A, T_J = 175^\circ C$		-	35	-	
Forward Transconductance	$V_{DS}=20V, I_D=30A$	gfs	-	16	-	S
Internal Gate Resistance	f=1MHz	RG	-	1.6	-	Ω
Input Capacitance	$V_{GS} = 0 V, V_{DS} = 600 V, f = 1MHz$	C_{iss}	-	2200	-	pF
Output Capacitance		C_{oss}	-	196	-	pF
Reverse Transfer Capacitance		C_{rss}	-	12	-	pF
Stored Energy in Output Capacitance		E_{oss}	-	39	-	μJ
Total Gate Charge(Note2)		Q_G	-	105	-	nC
Gate to Source Charge(Note2)	$I_D = 30A, V_{DD} = 400 V, V_{GS} = -4/+ 18 V$	Q_{GS}	-	28	-	nC
Gate to Drain Charge(Note2)		Q_{GD}	-	30	-	nC
Turn-on Delay Time(Note2)		$t_{d(ON)}$	-	13	-	ns
Rise Time(Note2)	$V_{DS} = 400 V, I_D = 30 A, V_{GS} = -4/+18 V, RG = 2.5 \Omega, L=200\mu H, T_J=25^\circ C$	t_r	-	16	-	ns
Turn-Off Delay Time(Note2)		$t_{d(OFF)}$	-	23	-	ns
Fall Time(Note2)		t_f	-	7	-	ns
Turn-on Switching Energy		Eon	-	82	-	μJ
Turn-off Switching Energy	Eoff	-	25	-	μJ	

Electrical Characteristics at Tc=25°C unless otherwise specified

Turn-on Delay Time(Note2)	VDS = 400 V, ID = 30 A, VGS = -4/+18 V, RG = 2.5 Ω L=200μH, Tj=175°C	t _{d(ON)}	-	12	-	ns
Rise Time(Note2)		t _r	-	15	-	ns
Turn-Off Delay Time(Note2)		t _{d(OFF)}	-	26	-	ns
Fall Time(Note2)		t _f	-	6	-	ns
Turn-on Switching Energy		Eon	-	60	-	μJ
Turn-off Switching Energy		Eoff	-	14	-	μJ

Source-Drain Diode Characteristics at Ta=25°C unless otherwise specified

Parameter	Test Condition	Symbol	Min.	Typ.	Max.	Unit
Maximun Body-Diode Continuous Current	VGS=-4V Tc=25°C	I _S	-	80	-	A
	VGS=-4V Tc=100°C		-	43	-	A
Maximun Body-Diode Pulsed Current(Note2)		I _{SM}	-	-	190	A
Drain-Source Diode Forward Voltage	VGS=-4V, ISD=15A Tj=25°C	V _{SD}	-	4.7	-	V
	VGS=-4V, ISD=15A Tj=175°C		-	4.2	-	V
	VGS=-4V, ISD=30A Tj=25°C		-	5.4	-	V
	VGS=-4V, ISD=30A Tj=175°C		-	48	-	V
Reverse Recovery Time(Note2)	VGS=-4V, ISD=30A,	trr	-	19	-	ns
Reverse Recovery Charge(Note2)	VR=400V,	Qrr	-	233	-	nC
Peak Reverse Recovery Current	di/dt=1797A/μs, Tj=25°C	Irrm	-	22	-	A
Reverse Recovery Time(Note2)	VGS=-4V, ISD=30A,	trr	-	22	-	ns
Reverse Recovery Charge(Note2)	VR=400V,	Qrr	-	334	-	nC
Peak Reverse Recovery Current	di/dt=1797A/μs, Tj=175°C	Irrm	-	26	-	A

Note2:Pulse test: 300 μs pulse width, 2 % duty cycle

RATINGS AND CHARACTERISTIC CURVES

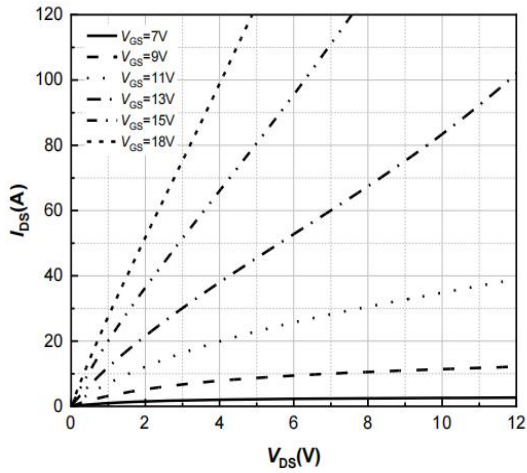

Figure 1. Output Characteristics
 $T_j = -40^\circ\text{C}$

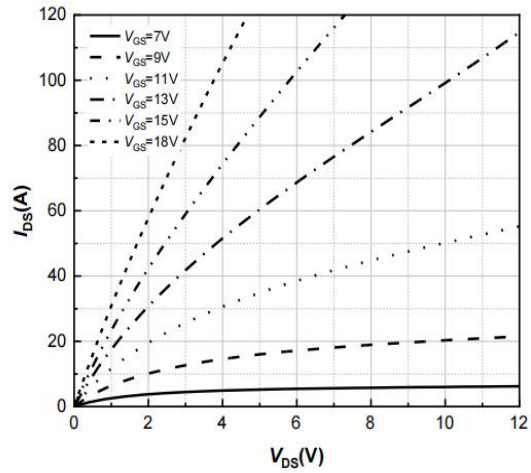

Figure 2. Output Characteristics
 $T_j = 25^\circ\text{C}$

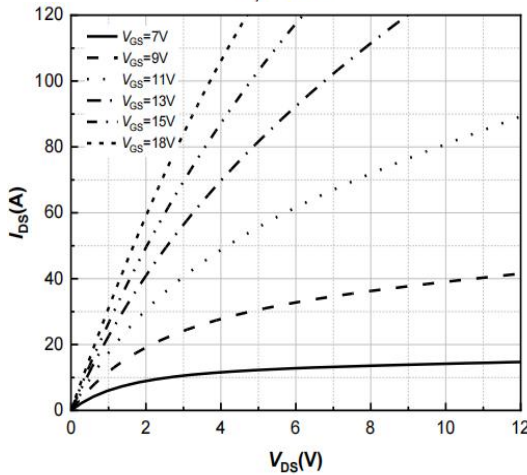

Figure 3. Output Characteristics
 $T_j = 175^\circ\text{C}$

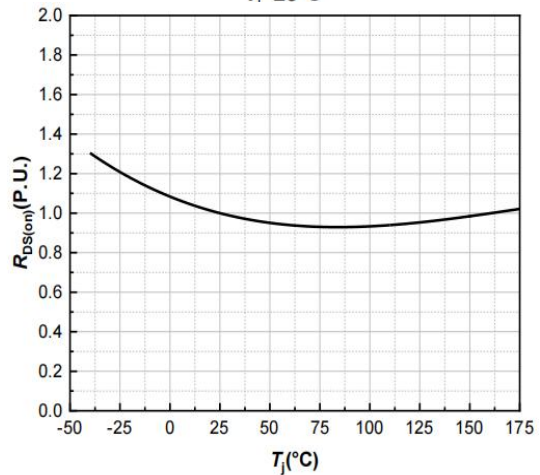

Figure 4. Normalized On-Resistance vs. Temperature

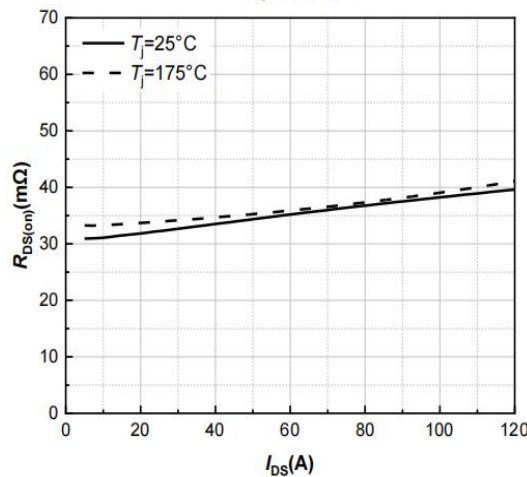

Figure 5. On-Resistance vs. Drain Current For Various Temperatures

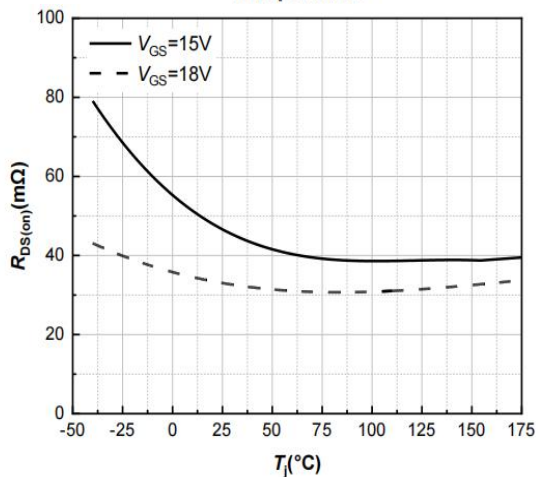

Figure 6. On-Resistance vs. Temperature For Various Gate Voltage

RATINGS AND CHARACTERISTIC CURVES

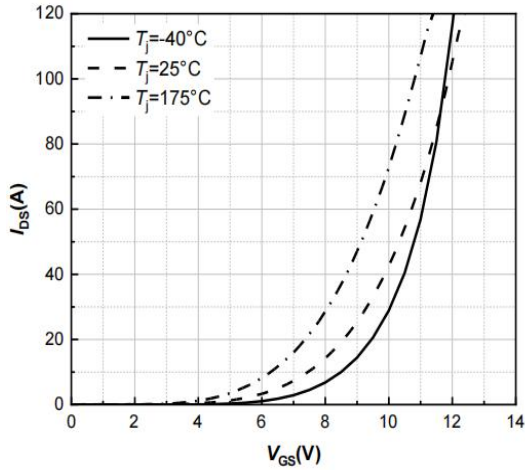

Figure 7. Transfer Characteristic for Various Junction Temperatures
 $V_{DS}=20V$

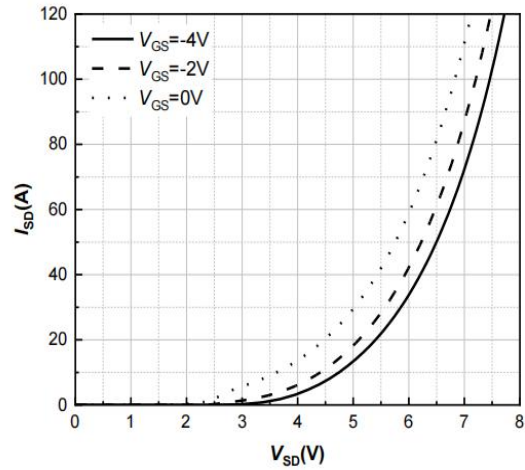

Figure 8. Body Diode Characteristic
 $T_J=-40^{\circ}C$

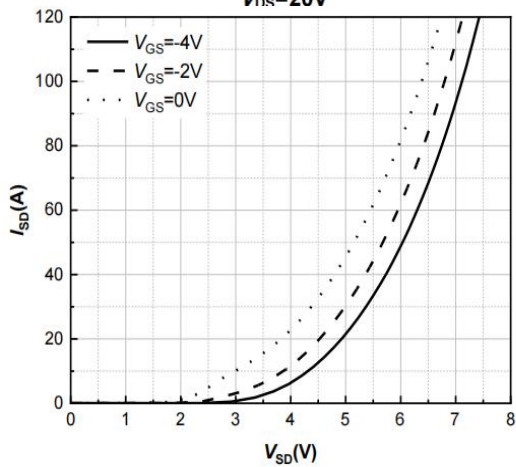

Figure 9. Body Diode Characteristic
 $T_J=25^{\circ}C$

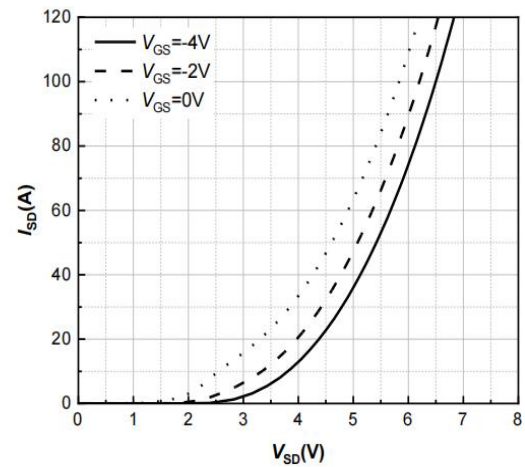

Figure 10. Body Diode Characteristic
 $T_J=175^{\circ}C$

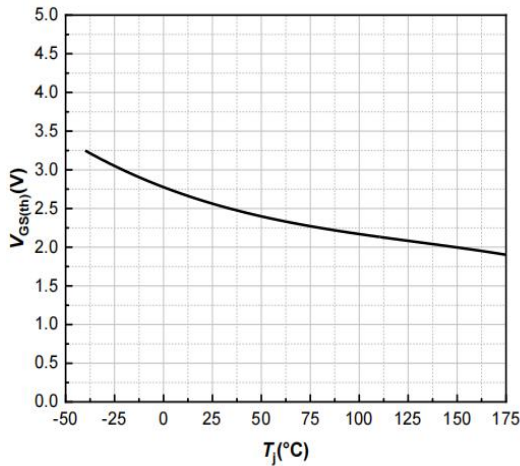

Figure 11. Threshold Voltage vs. Temperature

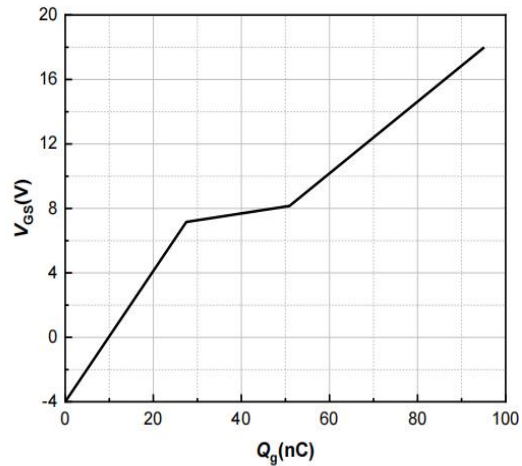

Figure 12. Gate Charge Characteristics

RATINGS AND CHARACTERISTIC CURVES

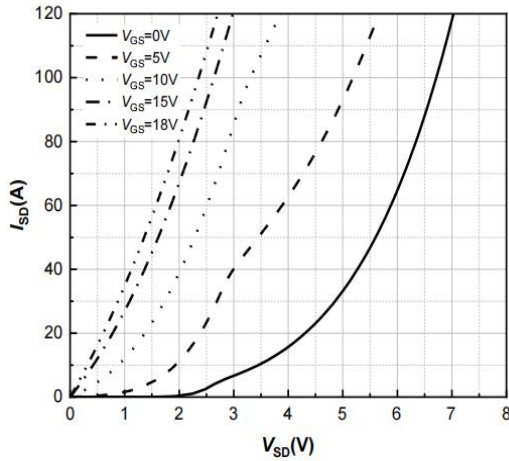

Figure 13. 3rd Quadrant Characteristic
 $T_j = -40^\circ\text{C}$

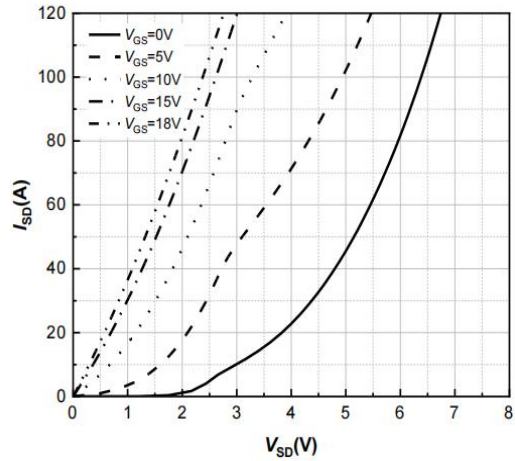

Figure 14. 3rd Quadrant Characteristic
 $T_j = 25^\circ\text{C}$

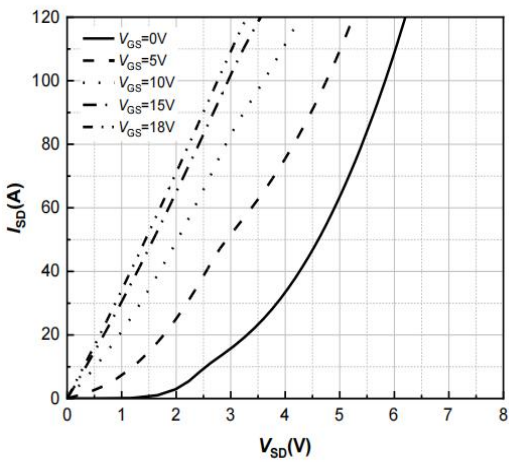

Figure 15. 3rd Quadrant Characteristic
 $T_j = 175^\circ\text{C}$

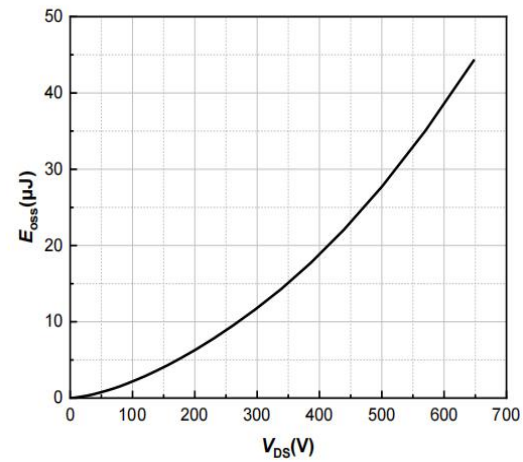

Figure 16. Output Capacitor Stored Energy

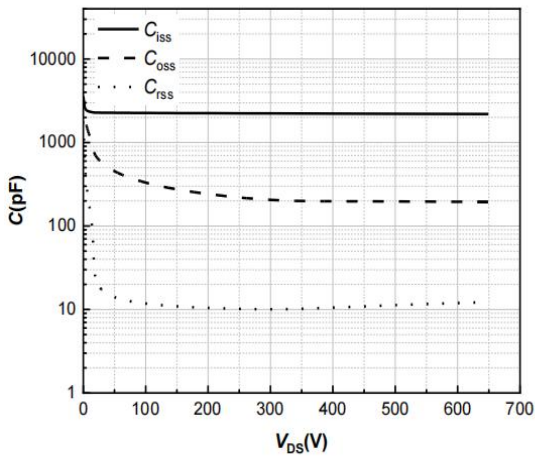
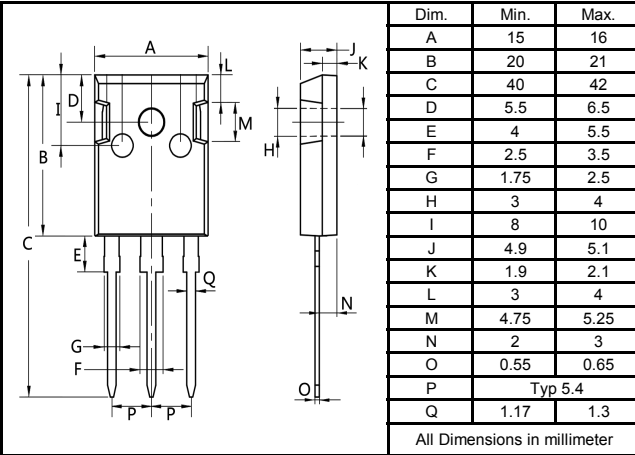

Figure 17. Capacitances vs. Drain-Source

Package Outline Dimensions millimeters



T0-247

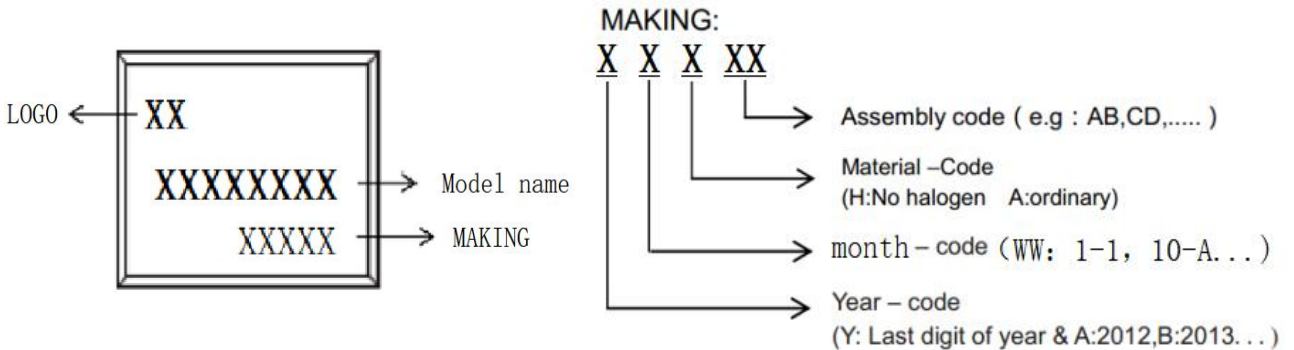

Marking on the body

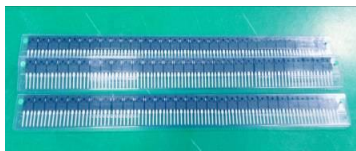

packing instruction

PKG	Minimal Package	Mini Box	Box
T0-247			
	30pcs/pdpe	600pcs/box	3000pcs/box

Notice

All product, product specifications and data are subject to change without notice to improve. The right to explain is owned by LINGXUN electronics company.

Confirm that operation temperature is within the specified range described in the product specification. Avoid applying poer exceeding normal rated

poer; exceeding the power rating under steady-state loading condition may negatively affect product performance and reliability.

LINGXUN electronics shall not be in any way responsible or liable for failure induced under deviant condition from what is defined in this document.

<http://www.lxmicro.com>

Revision History

Rev	Changes	Date
1.0	First version	2025/8/30